

A Bible - Based Reading Project

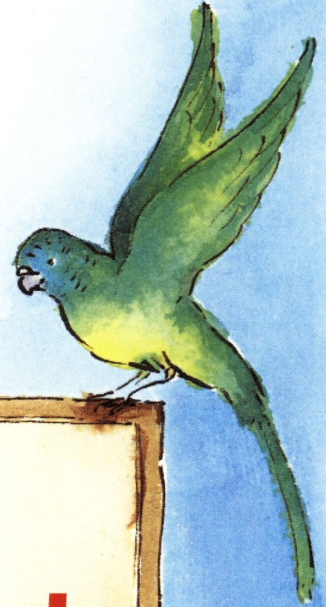

DIAMOND BOOKS™

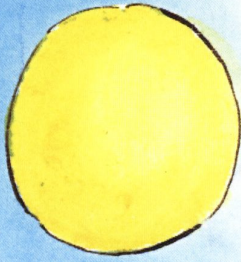

# Creation Activity Book

Compiled by Carole Leah  
Illustrated by Sharon Lewis

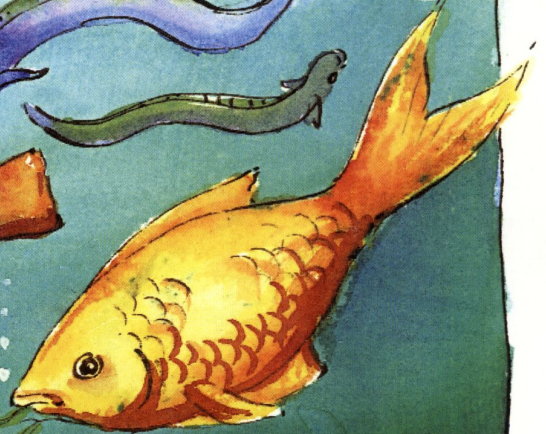
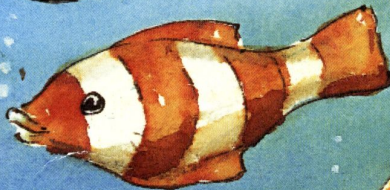
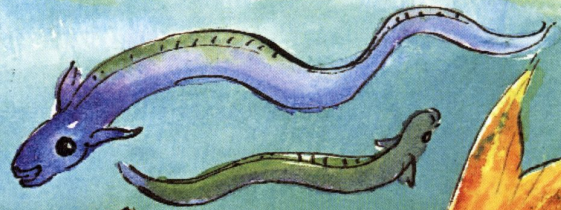

## ACKNOWLEDGMENTS

I would like to thank all the friends and colleagues who have contributed to this project. Thanks are particularly due to Lynne Jaques and Elizabeth McAsey for most of the ideas in this book. The greatest gratitude goes to Almighty God Himself who has enabled and provided for the compilation of this book.

Have fun!

Carole Leah

## DEDICATION

*THIS SERIES WITH ITS SUPPLEMENTARY MATERIALS IS DEDICATED TO THE MEMORY OF MY DEAR FRIEND RUTH MARTIN who gave me so much support with the project.*

Published in 2001 by Diamond Books, c/o CPO, Garcia Estate,  
Canterbury Road, Worthing, West Sussex BN13 1BW, UK

Ref CPO3084

Text copyright © Carole Leah 2001

Illustration copyright © Sharon Lewis 2001

Carole Leah and Sharon Lewis assert their right to be identified as the compiler and illustrator of this work in accordance with the Copyright, Design and Patents Act, 1988

Computer graphics, layout and typesetting by John Hodge

All rights reserved. No part of this publication may be reproduced, stored in a retrieval system, or transmitted in any form or by any means, electronic, mechanical, recording or otherwise, without the prior permission of Diamond Books, 'Oakleah', 85 Cornelius Drive, Pensby, Wirral, Merseyside, CH61 9PZ, UK, EXCEPT when used in conjunction with the eight books of Set A

ISBN 1-901796-33-7

Printed, bound and distributed by CPO, Garcia Estate,  
Canterbury Rd, Worthing, West Sussex, BN13 1BW, UK

---

## LETTER AND NUMBER FORMATION CHART

The dots show the starting places of the letters and numbers  
and the directional arrows show the way to form them.

a b c d e f g h i j k l m n

o p q r s t u v w x y z

1 2 3 4 5 6 7 8 9

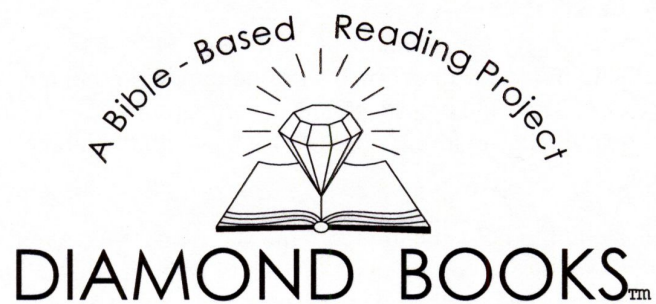

# Creation Activity Book

Compiled by Carole Leah

Illustrated by Sharon Lewis

## Dear Parents and Teachers

All the material in this activity book is photocopiable on the condition that it is used in conjunction with the eight books of Set A. The sixty activity sheets accompany the Set A *Creation Series* of Diamond Books for 3-4 year olds. The four games are for use with the *Creation Sounds* audio cassette tape.

The activity sheets are designed to help children gain the skills they need to be ready to learn to read (see Index, page 68). All the activities can be used by a child with an adult. The brief instructions on each page suggest ideas for the child to do. They are *not* scripts: the activities will need to be explained carefully and the pictures discussed, etc. There are symbols on each page telling the child what sort of activity to expect (see below). Any activity sheet can be used for colouring (and some would be more suitable for this purpose if enlarged).

Several of the activity sheets contain letters or numbers for the child to write over. It is very important that these are formed correctly by a child. A chart showing dots and directional arrows for letter and number formation is shown on the inside front cover.

In the *Creation Series*, eight particular characteristics of God the Creator, reflected in His creation, are emphasised. One of these is printed at the top of each activity sheet, as a possible point of discussion.

I hope you will find these activities useful and that you with the children will have fun together in doing them.

Caroleah

### Symbols for the children:



Counting



Cutting



Dot-To-Dot



Drawing



Extra Activities



Glueing



Jigsaw



Letter Formation Practice

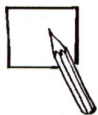

Pencil Practice



Sorting

# C O N T E N T S

Acknowledgments, Dedication, Publishing Details and Letter and Number Formation Chart . . . . .	Inside front cover
Activities for Book 1 (of Set A) . . . . .	Pages 4-10
Activities for Book 2 (of Set A) . . . . .	Pages 11-16
Activities for Book 3 (of Set A) . . . . .	Pages 8, 17-23
Activities for Book 4 (of Set A) . . . . .	Pages 24-30
Activities for Book 5 (of Set A) . . . . .	Pages 31-38
Activities for Book 6 (of Set A) . . . . .	Pages 39-47
Activities for Book 7 (of Set A) . . . . .	Pages 48-54, 60
Activities for Book 8 (of Set A) . . . . .	Pages 55-61
Activities for Books 1-8 (of Set A) . . . . .	Pages 62-63
Game cards for Creation Sounds audio cassette tape . . .	Pages 64-67
Index . . . . .	Page 68
Advertisements for other Diamond Books and Materials . . . . .	Inside back cover

### Activity 1

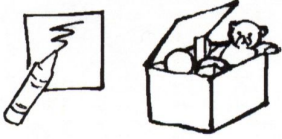

### (Book 1)

In Book 1, find 2 monkeys, 3 jellyfish, 4 stars, 5 flowers and 8 tentacles on the octopus. Find each of these groups on the activity sheet and colour them in.

123



**Activity 2****(Book 1)**

Find the same picture in the book. What's missing on the activity sheet?

Add the missing features to the picture.

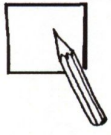

**Activity 3****(Book 1)**

Look at pages 14-15 in Book 1.

On the activity sheet, draw lines at random from left to right (—————>) on the puffin, flamingo and fish. (Some have already been drawn across the puffin as examples.)

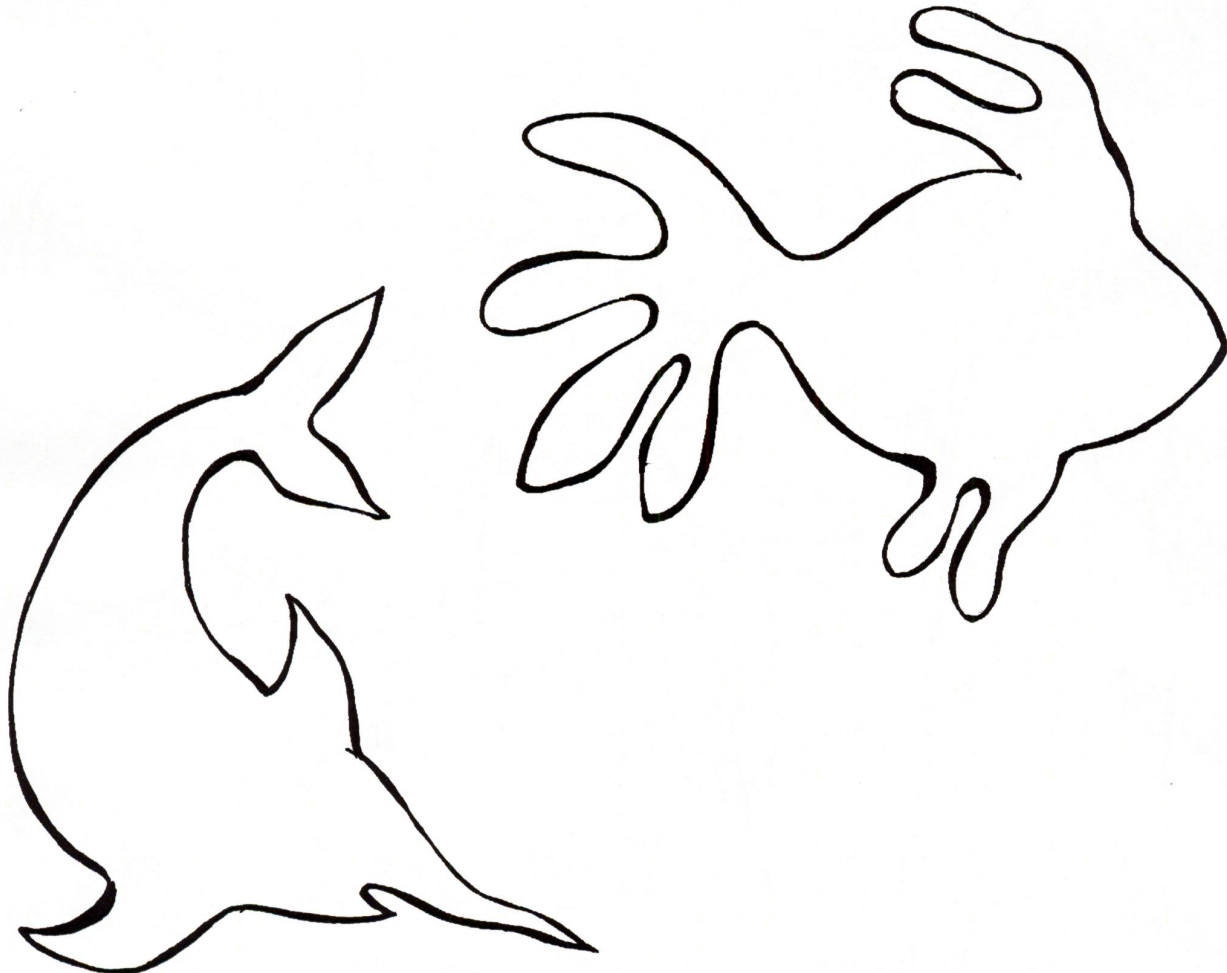
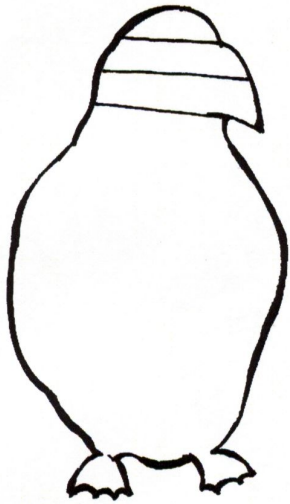

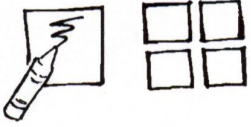

**Activity 4****(Book 1)**

Find the elephant in Book 1 and compare it with the colour of the elephant on this activity sheet.

Colour this elephant grey.

Cut along the broken lines.

Make the pieces into a simple jigsaw.

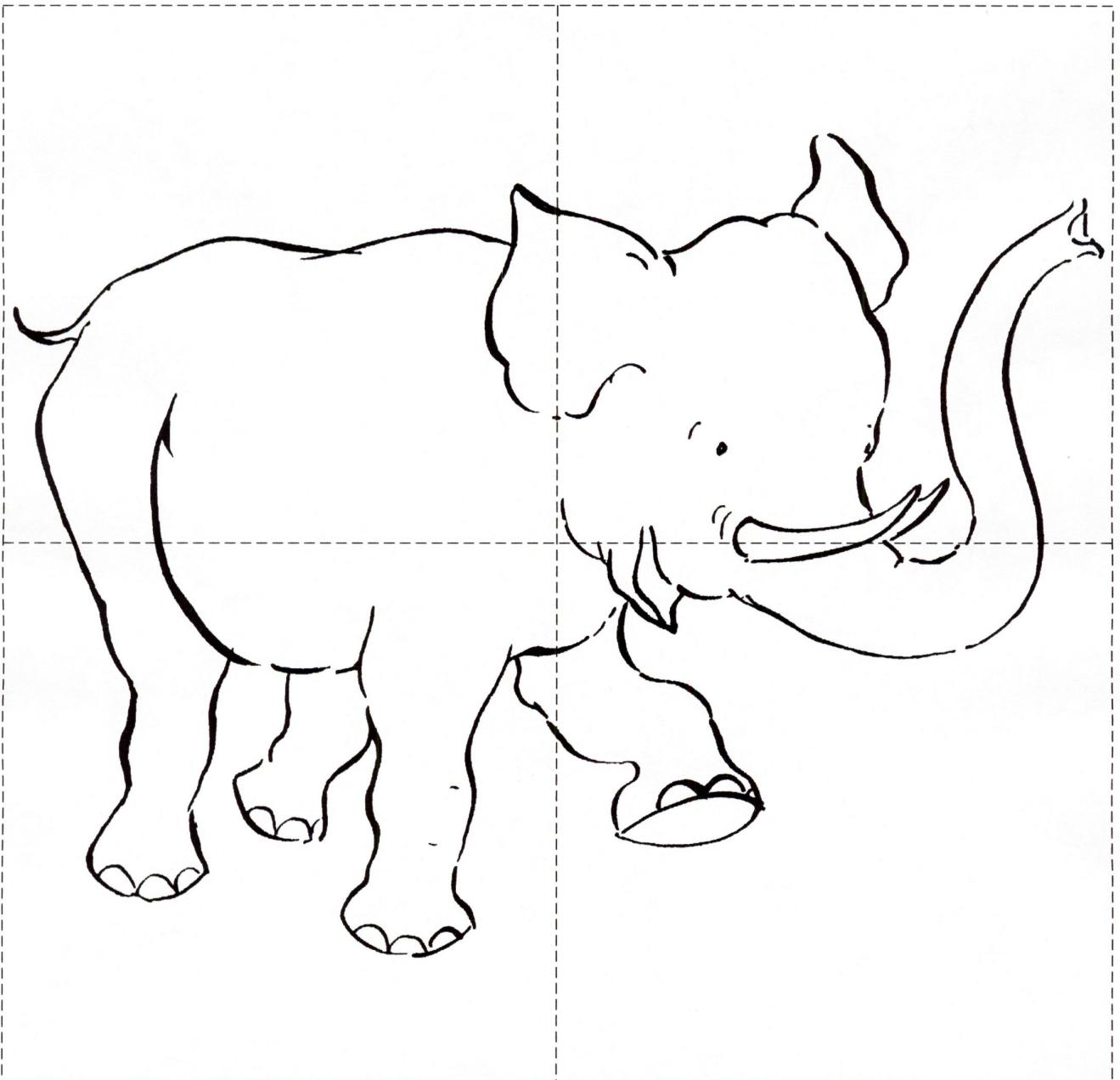

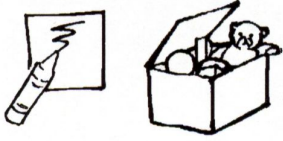
**Activity 5****(Books 1 and 3)**

Look at all the sky pictures in Books 1 and 3. Compare them with the sky picture on this activity sheet. Is this a proper sky picture? Why not?

Using a different coloured crayon for each group, draw lines to join the suns, the moons and the stars.

Discuss the different shapes.

Colour the suns and moons in yellow.

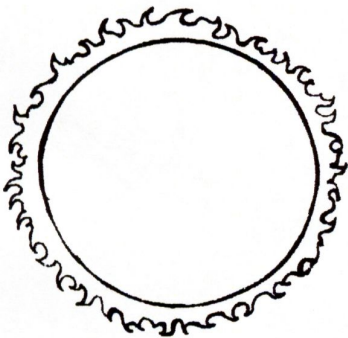
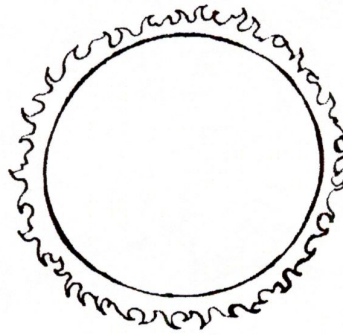

**Activity 6****(Book 1)**

Look at the picture on pages 20-21 of Book 1. Compare it with the activity sheet picture. Discuss what parts are missing and draw them in, e.g., grass, water, flamingo and flower.

Find the letters 'b' and 'g'. Colour the 'b' parts brown and the 'g' parts green.



### Activity 7



### (Book I)

Look at Book I and then discuss what God made and did on Days 1-7.

On this activity sheet, draw lines to match the number of the day with what God did on that day.

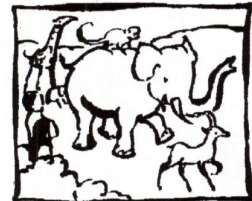
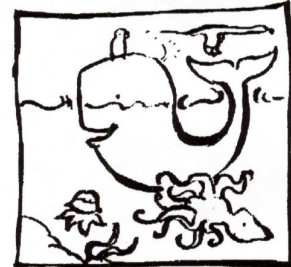
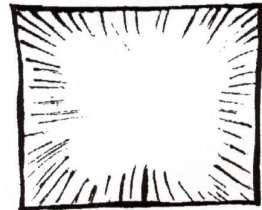
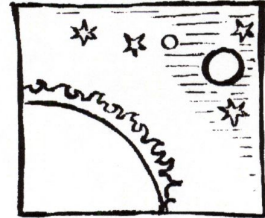

### Activity 8



(Book 2)

Look at the seaside picture in Book 2. On the activity sheet, join the dots from left to right and from top to bottom.

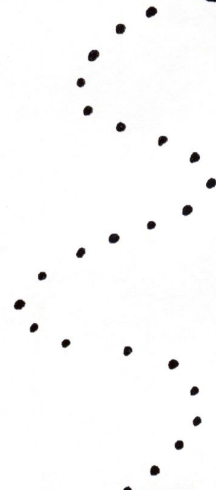
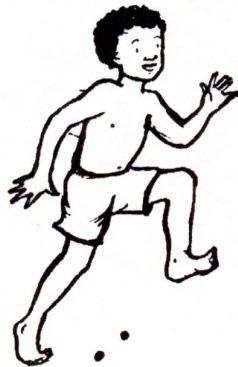

**Activity 9**

123

**(Book 2)**

Look at all the flying things in the sky in Book 2.

On this activity sheet, count the different items.

Colour the sky blue and grey and then the aeroplane and balloons.

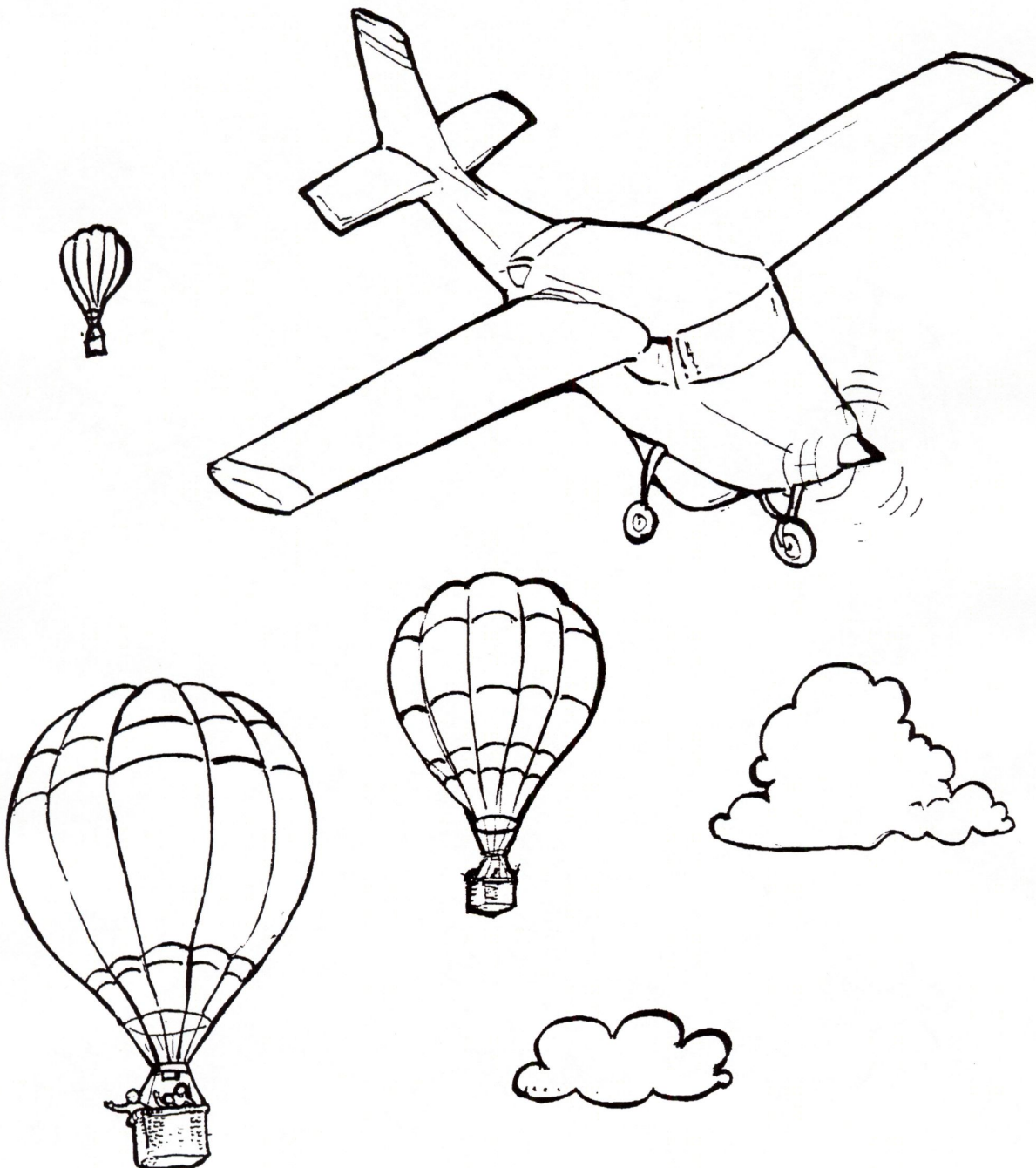

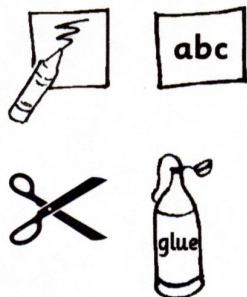
**Activity 10****(Book 2)**

Look at the picture on page 9 of Book 2. Discuss day and night.

On this activity sheet, use blue/black to colour the semi-circle at the bottom. Cut out this semi-circle along the broken lines. Glue the semi-circle onto the circle.

Write letters on the dots. Remember to start each letter at the big spot.

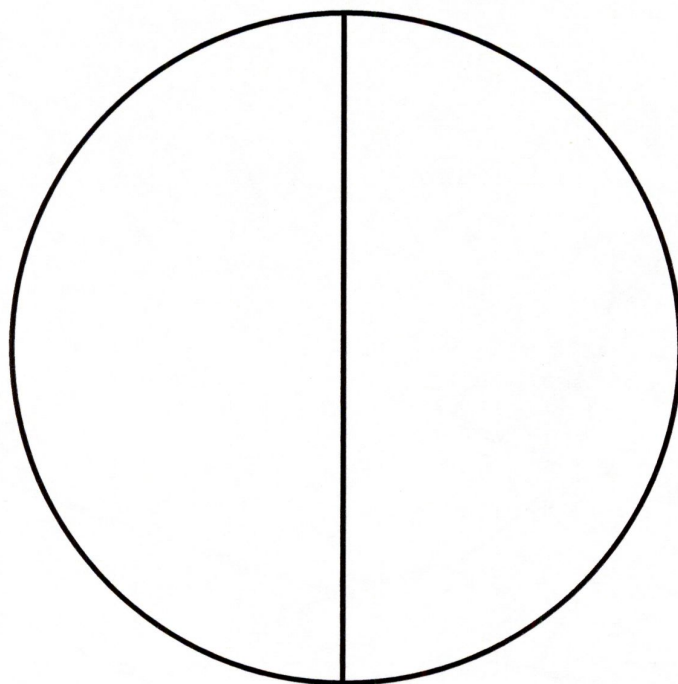

day

night

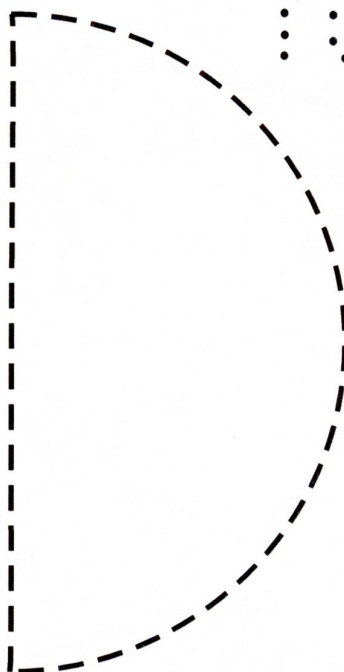

**Activity II****(Book 2)**

Find the aeroplane in Book 2.

On this activity sheet, colour the aeroplane.

Cut along the broken lines.

Use the pieces to make a jigsaw.

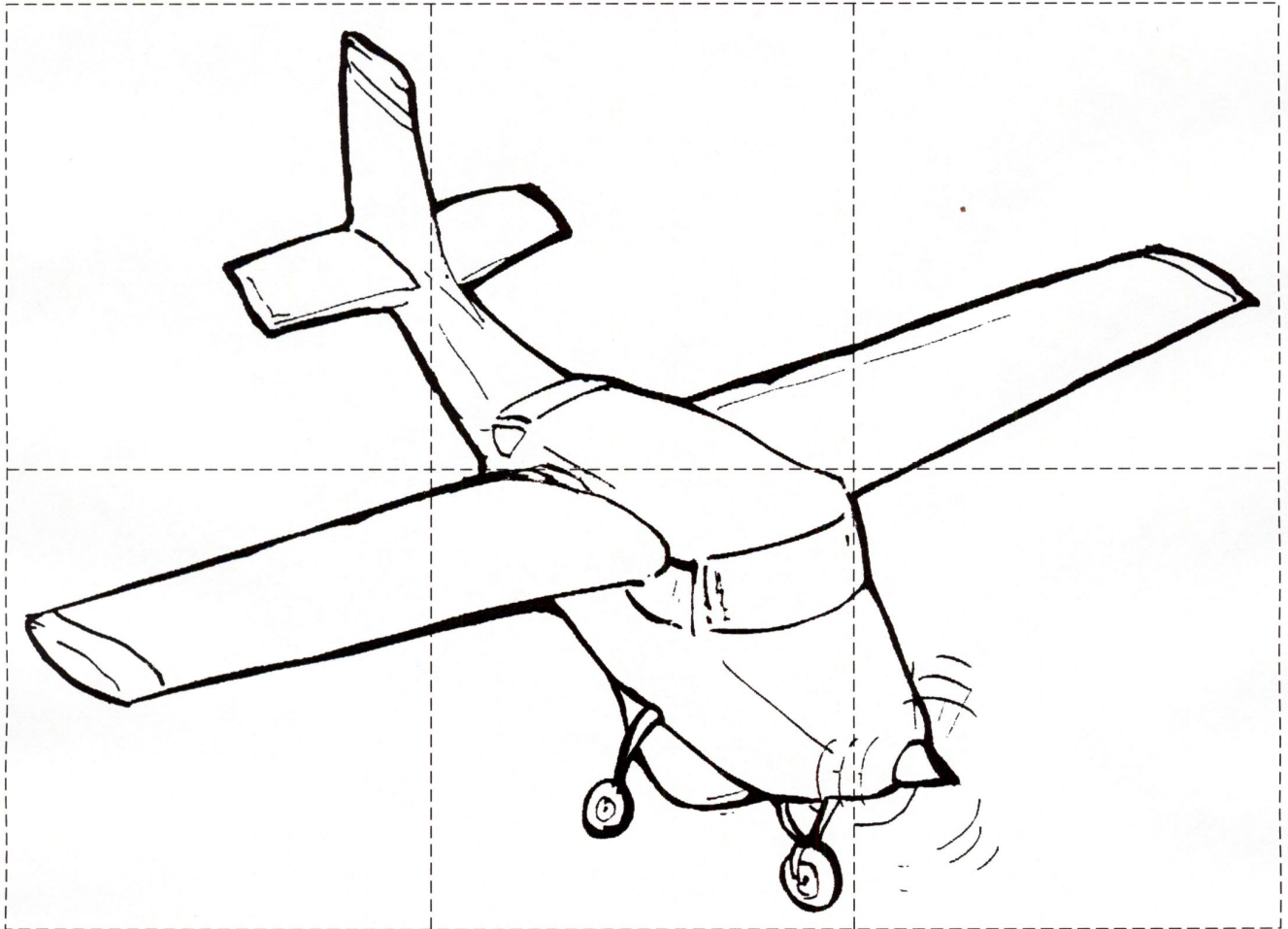



### Activity 12

(Book 2)

Look at pages 22 and 23 in Book 2. Discuss the different times of the day.  
On the activity sheet, colour the pictures. Cut them out along the broken lines.  
Sort the pictures into the order of events.

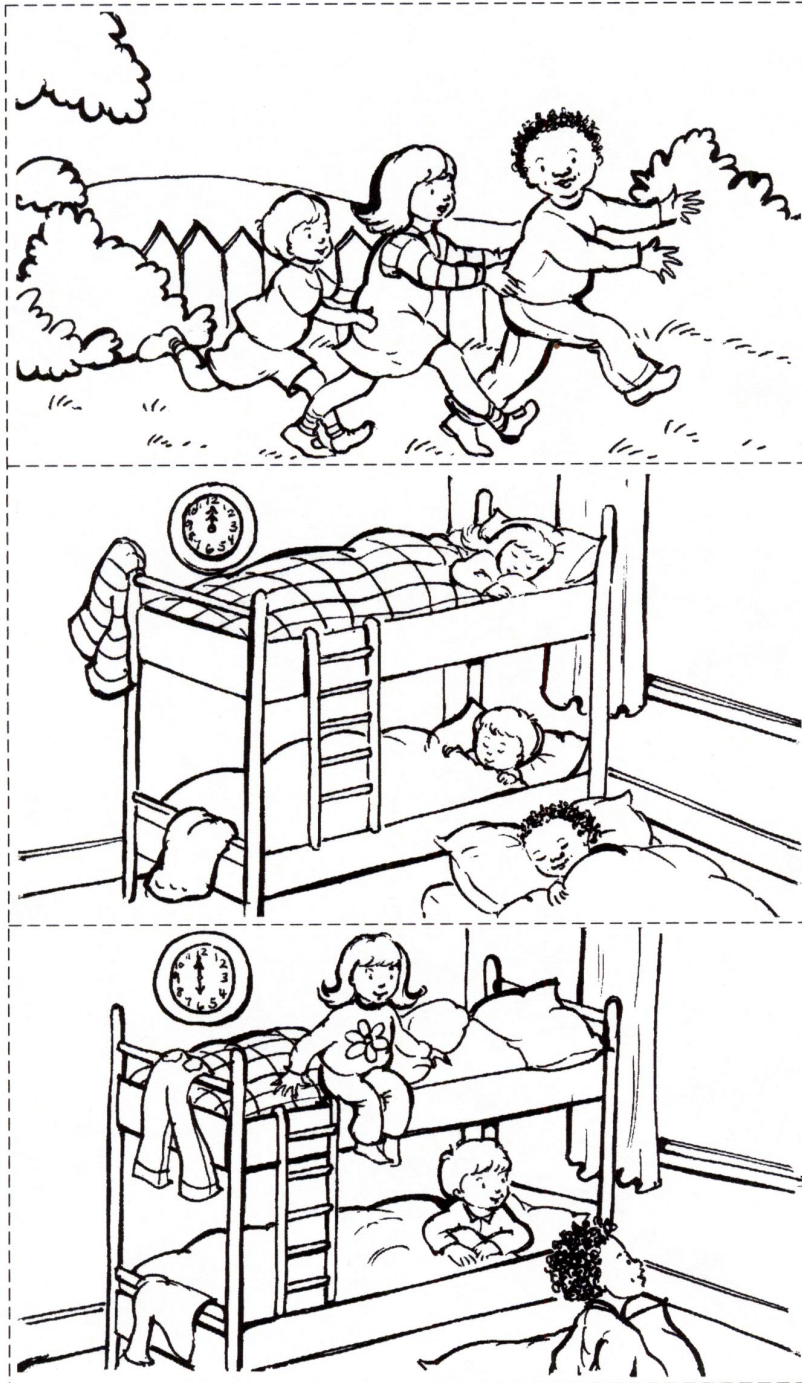

**Activity 13****(Book 2)**

Look at pages 16 and 17 in Book 2.

On the activity sheet, draw 3 stones on the high ground and 4 stones on the low ground. Colour the 3 stones, yellow and the 4 stones, green.



123

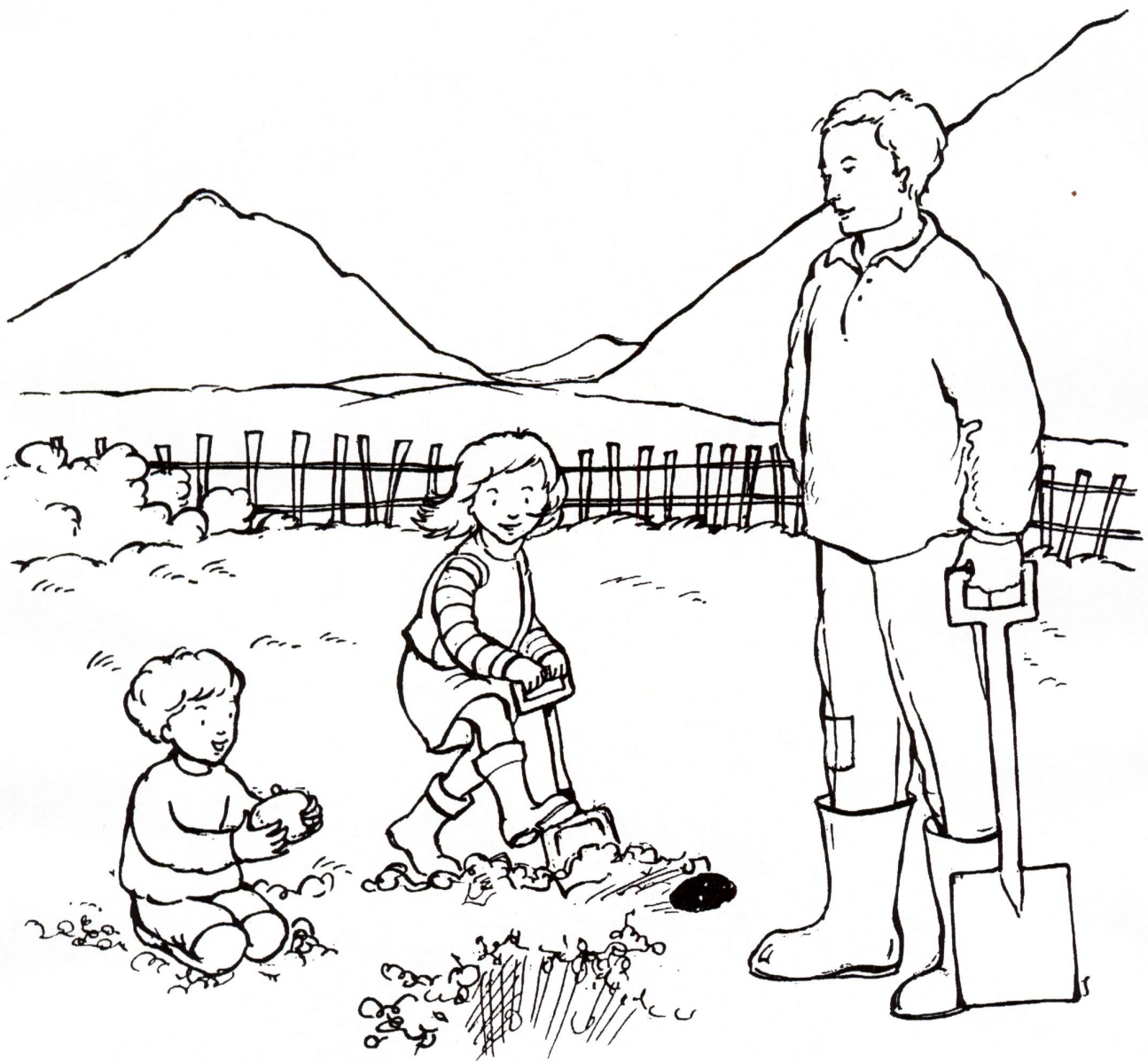

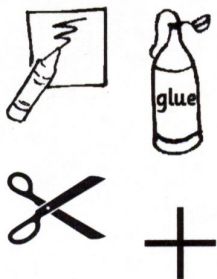
**Activity 14****(Book 3)**

Find all the daisies in Book 3. Discuss the names of the different parts of the flowers.

On the activity sheet, colour the stems, green and the centres, yellow.

Cut along the broken lines.

Glue the daisies onto the circle.

Look at some seeds, e.g., mustard/cress. Discuss necessary growing conditions.

Place seeds on damp cotton wool/soft lint. Place in dark. Check each day.

When germination begins bring into the light. Keep well watered. Discuss

bulbs. Pretend to be bulbs pushing through the cold earth and growing.

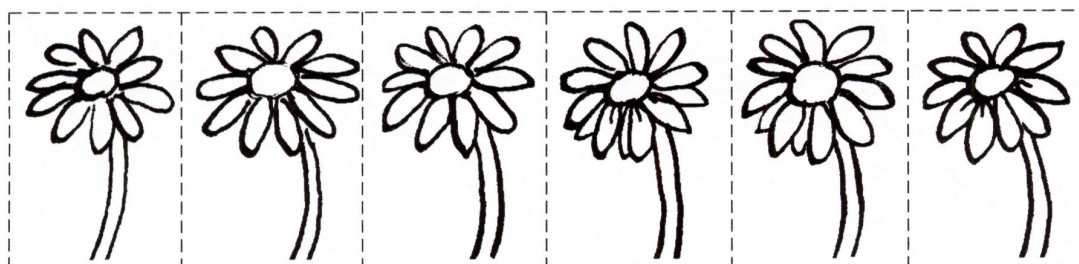
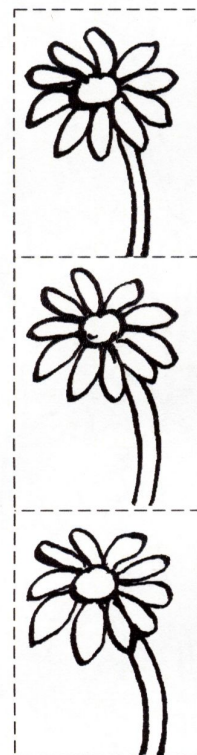
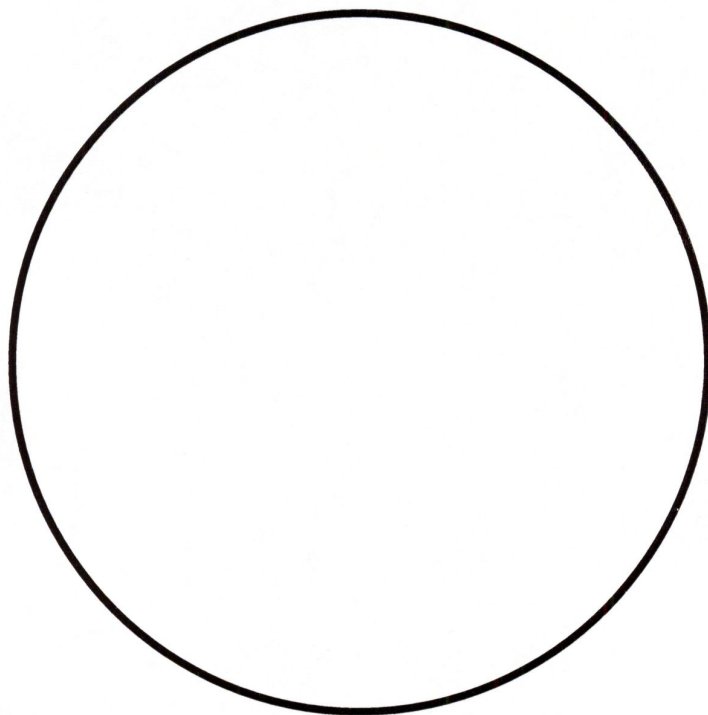

**Activity 15****(Book 3)**

Look at all the flowers in Book 3. Discuss them.

Pick a real flower and put it in a container. Discuss its colour, name and parts. Draw the flower inside the frame on this activity sheet, using crayons, pastels, felt-tipped pens or paints.

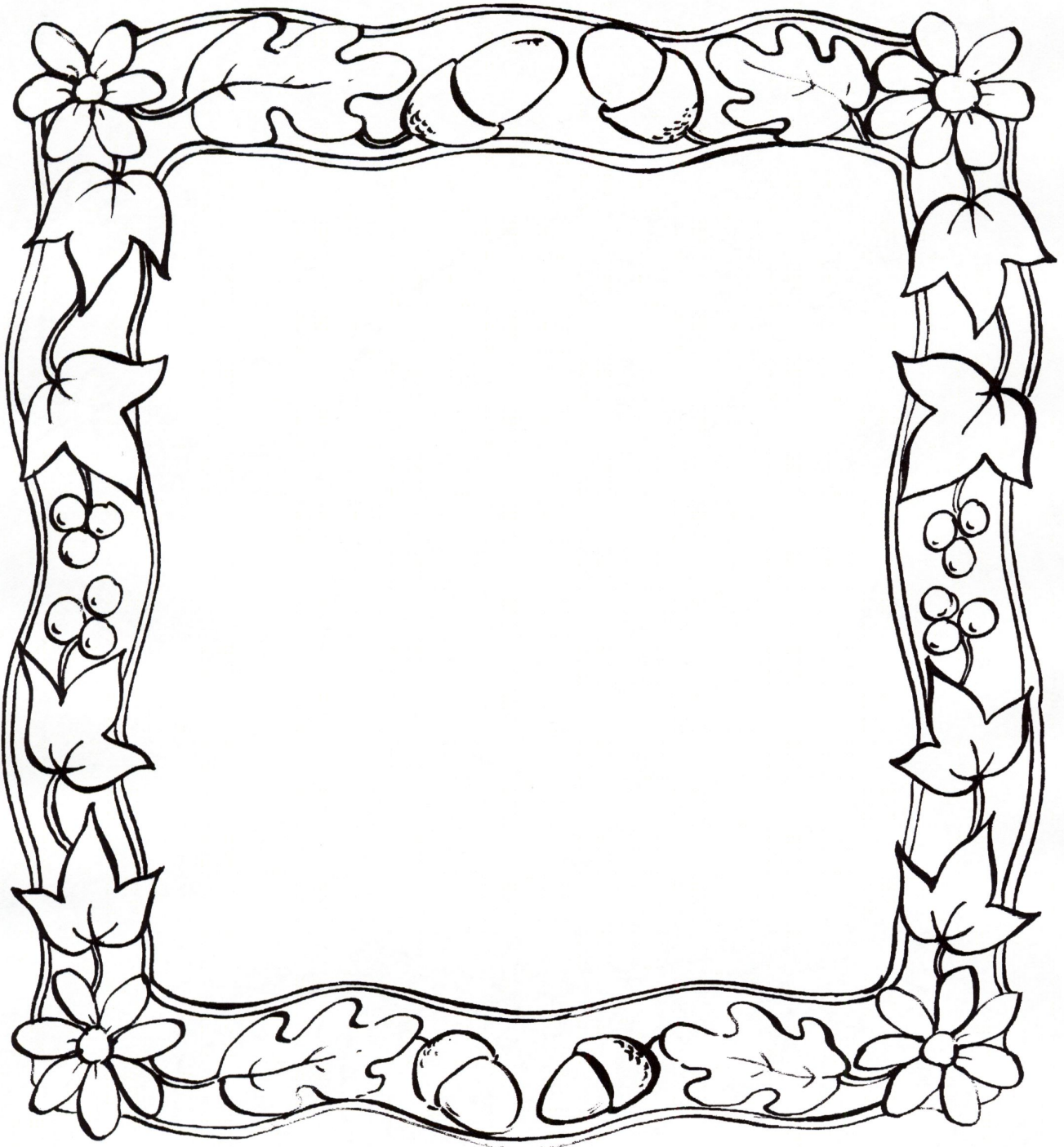

## Activity 16



### (Book 3)

Find the picture of fruits and vegetables in Book 3.

On the activity sheet, colour the items.

Use a red crayon to join up all the fruits and a green crayon to join all the vegetables.

Go over the dots with a pencil to make the words. Remember to start each letter at the big spot.



cabbage

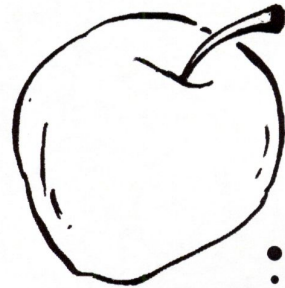

apple

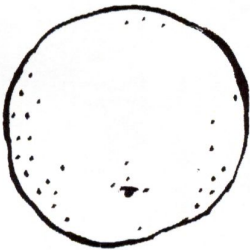

orange

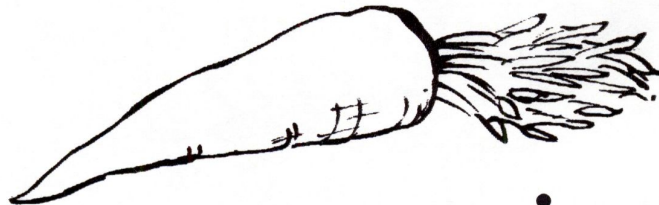

carrot

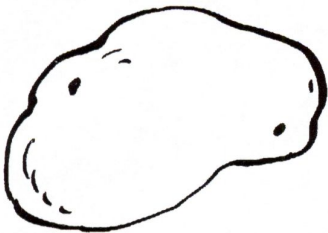

potato

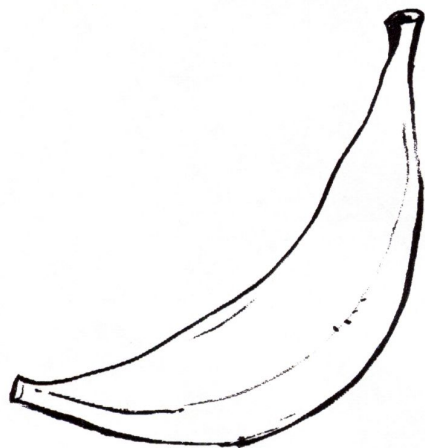

banana

**Activity 17****(Book 3)**

Look at the trees on the activity sheet.

Find the same ones on pages 15-21 of Book 3. Discuss the different trees.

Cut along the broken lines.

Sort the trees into a seasonal sequence.



## Activity 18

(Book 3)

Look in Book 5. Discuss the senses used in the illustrations.

On the activity sheet identify each sense.

Use a pencil to go over the dotted initial letter of each sense word. Remember to start each letter at the big spot.

abc

ight



aste

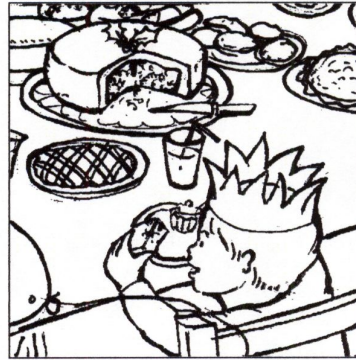

earing



mell



ouch



**Activity 19**

123

**(Book 3)**

Look for the daffodils, tulips and bluebells in Book 3.

On the activity sheet, colour the daffodils yellow, the tulips red and the bluebells blue.

Count all the flowers.

Use a pencil to write over the dots of 9. Remember to start the number at the big spot.

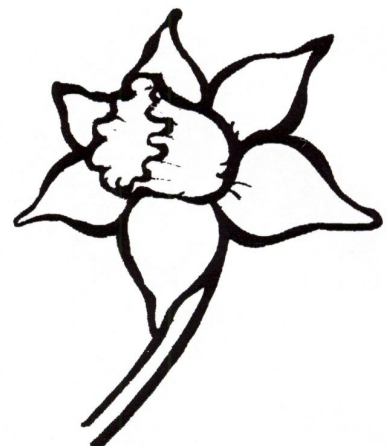
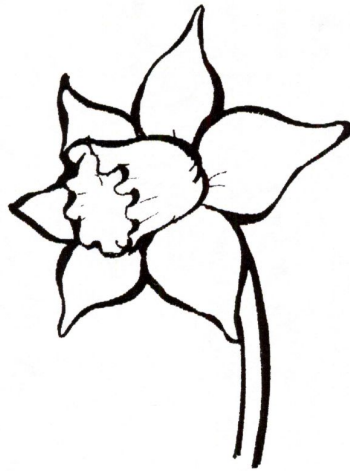
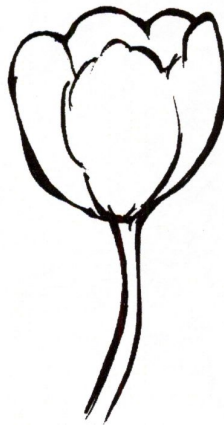



### Activity 20



### (Book 3)

Look at the picture of fruits and vegetables growing near the ground on page 7 of Book 3. Discuss.

On the activity sheet, join up the dots with a brown crayon from left to right (→).

Discuss the vegetables that grow above and below the ground.

Cut along the broken lines.

Stick the pictures either above or below the brown line.

ground .....

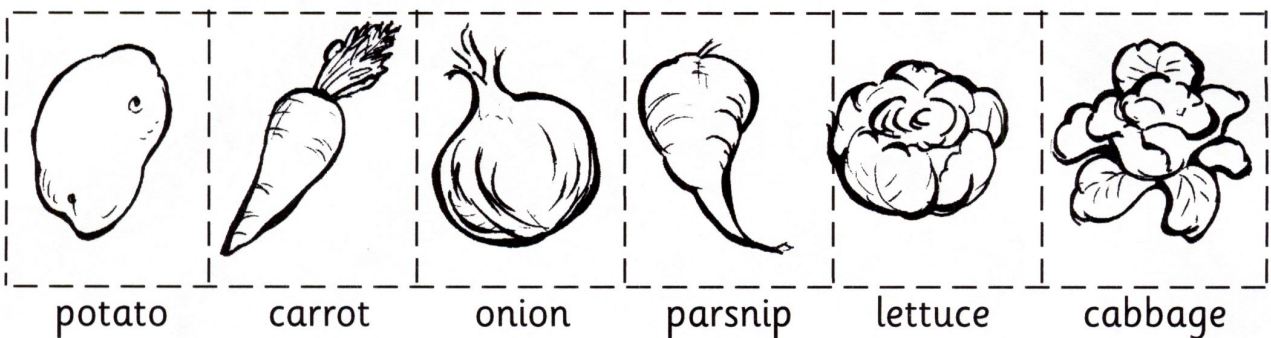

### Activity 21

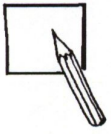

#### (Book 4)

Look at the sea creatures on pages 10-11 of Book 4. Discuss.

On the activity sheet, find pairs of the same sea creature. Draw a line between each pair.

Use a pencil to join up the dots of the initial letters. Remember to start each letter at the big spot.

Copy these letters underneath.

